

SECTION 702. Change in Use

No change shall be made in the character of occupancy or use of **any building** which would place the building in a different division of the same group of occupancy or in a different group of occupancies, unless such building is made to comply with the requirements of the **Code** for such division or group of occupancy. The character of occupancy of existing buildings may be changed subject to the approval of the **Building Official** and the building may be occupied for purposes set forth in other Groups: Provided the new or proposed use is less hazardous, based on life and fire risk, than the existing use.

SECTION 703. Mixed Occupancy

1. General Requirements

When a building is of **mixed occupancy** or used for **more than one occupancy**, the whole building shall be subject to the **most restrictive requirement** pertaining to any of the type of occupancy found therein except in the following:

- a. When a **one-storey building** houses more than one occupancy, each portion of the building shall conform to the requirement of the particular occupancy housed therein and;
- b. Where minor accessory uses do **not** occupy more than 10% of the area of any floor or a building, nor more than 10% of the basic area permitted in the occupancy requirements, in which case, the **major use** of the building shall determine the occupancy classification.

2. Forms of Occupancy Separation

Occupancy separations shall be vertical or horizontal or both, or when necessary, of such other forms as may be required to afford a **complete separation** between the various occupancy divisions in the building.

3. Types of Occupancy Separation

Occupancy separation shall be classified as “**One-Hour Fire-Resistive**”, “**Two-Hour Fire-Resistive**”, “**Three-Hour Fire-Resistive**” and “**Four-Hour Fire-Resistive**.”

- a. A “**One-Hour Fire-Resistive** Occupancy Separation” shall be of **not less than one-hour fire-resistive construction**. All openings in such separation shall be protected by a fire-assembly having a one-hour fire-resistive rating.
- b. A “**Two-Hour Fire-Resistive** Occupancy Separation” shall be of **not less than two-hour fire-resistive construction**. All openings in such separation shall be protected by a fire assembly having a two-hour fire-resistive rating.
- c. A “**Three-Hour Fire-Resistive** Occupancy Separation” shall be of **not less than three-hour fire-resistive construction**. All openings in walls forming such separation shall be protected by a fire assembly having a three-hour fire-resistive rating. The total width of all openings in any three-hour fire-resistive occupancy separation wall in any one-storey shall not exceed 25% of the length of the wall in that storey and no single opening shall have an area greater than 10.00 sq. meters. All openings in floors forming a “Three-Hour Fire-Resistive Occupancy Separation” shall be protected by vertical enclosures extending above and below such openings. The walls of such vertical enclosures shall be of not less than two-hour fire-resistive construction, and all openings therein shall be protected by a fire assembly having a three-hour fire-resistive rating.

- d. A “**Four-Hour Fire-Resistive Occupancy Separation**” shall have no openings therein and shall be of **not less than four-hour fire-resistive construction**.

4. Fire Rating for Occupancy Separation

Occupancy Separations shall be provided between groups, subgroupings, or divisions of occupancies. The Secretary shall promulgate rules and regulations for appropriate occupancy separations in buildings of mixed occupancy; Provided, that, where any occupancy separation is required, the minimum shall be a “One-Hour Fire-Resistive Occupancy Separation”; and where the occupancy separation is horizontal, structural members supporting the separation shall be protected by an equivalent fire-resistive construction.

SECTION 704. Location on Property

1. General

- a. **No building shall be constructed unless it adjoins or has direct access to a public space, yard or street on at least one of its sides.**
- b. For the purpose of this Section, the centerline of an adjoining street or alley shall be considered an adjacent property line.
- c. Eaves over required windows shall not be less than 750 millimeters from the side and rear property lines.

2. Fire Resistance of Walls

Exterior walls shall have fire resistance and opening protection in accordance with the requirements set forth by the Secretary. Projections beyond the exterior wall shall not exceed beyond a point one-third the distance from an assumed vertical plane located where the fire-resistive protection of openings is first required to the location on property whichever is the least restrictive. Distance shall be measured at right angles from the property line. When openings in exterior walls are required to be protected due to distance from property line, the sum of the areas of such openings in any storey shall not exceed 50% of the total area of the wall in that storey.

3. Buildings on Same Property and Buildings Containing Courts

For the purpose of determining the required wall and opening protection, buildings on the same property and court walls shall be assumed to have a property line between them. When a new building is to be erected on the same property with an existing building, the assumed property line from the existing building shall be the distance to the property line for each occupancy as set forth by the Secretary; Provided, that two or more buildings on the same property may be considered as one building if the aggregate area of such building is within the limits of allowable floor areas for a single building, and when the buildings so considered, house different occupancies or are of different types of construction, the area shall be that allowed for the most restrictive occupancy or construction.

4. **Building Footprint and Firewall Requirements**

- a. The following rules shall be observed in the determination of the Allowable Maximum Building Footprint (**AMBF**) for buildings and related **habitable** structures. If the stated rules are compared with (1) **Rule VIII Table VIII.1.-** Reference Table on Percentage of Site Occupancy and Maximum Allowable Construction Area (**MACA**); (2) **Rule VIII Tables VIII.2. and VIII.3.** (setbacks, yards and courts); or (3) with the applicable stipulations under this Rule and with the

applicable stipulations of the **Fire Code**, **the more stringent but applicable regulation out of the aforementioned rules should be observed;**

- b. If **without a firewall**, the footprint of a proposed building/structure shall be measured horizontally from the property line to the outermost faces of the exterior walls of the building/structure; Provided, that the distance measured from the property line shall conform with the applicable stipulations of **this Rule and Rule VIII**; The resultant area established at grade level upon which the proposed building/structure may stand shall be the **AMBF**;
- c. Footprint Based on **Firewall Provisions**
 - i. If with a **firewall on one (1) side**, the footprint of a proposed building/structure shall be measured horizontally from the property line with a firewall to the outermost faces of the opposite exterior walls of the building/structure; Provided, that the applicable stipulations of the **Fire Code** are strictly followed;
 - ii. If with a **firewall on two (2) sides** or on one (1) side and the rear property line, the footprint of a proposed building/structure shall be measured horizontally from the opposing property lines in case of a firewall on two (2) sides or from the rear property line with a firewall to the outermost faces of the opposite exterior walls of the building/structure; provided, that the applicable stipulations of the Fire Code are strictly followed;
 - iii. **Absolutely no firewalls are allowed for a low density residential (R-1) uses or occupancies;** an **abutment of up to 3.20 meters** from established grade level may however be permitted but solely **for the purpose of supporting a carport roof**; provided further that such abutment shall be constructed of perforated or decorative concrete blocks above 1.50 meters measured vertically from the established grade level; such an abutment shall not be longer than 7.00 meters or 50% of the side property line in total length, whichever is shorter.
 - iv. For **medium density residential (R-2)** uses or occupancies, **a firewall can be erected on a maximum of 80% of the total length of a side property line;** provided that **only one (1) side property line is used for a firewall** in the case of a R-2 structure; and provided further that the applicable stipulations of the Fire Code are strictly followed;
 - v. For **high-density residential (R-3)** uses or occupancies, **two (2) types of firewall construction may be permitted:**
 - (a) For a **R-3 use or occupancy with a firewall on two (2) sides**, a firewall can be erected on a maximum of 85% of the total length of each side property line; provided that all firewall construction shall not exceed 65% of the total perimeter of the R-3 property, i.e., total length of all property lines; provided that firewalls in R-3 lots shall only be allowed for a maximum two (2) storey component structure; and provided further that all the applicable stipulations of the Fire Code are strictly followed; and
 - (b) For a **R-3 use or occupancy with a firewall on one (1) side property line and at the rear property line**, a firewall can be erected on a maximum of 90% of the total length of the side and rear property lines and up to 100% in case the rear property line is only 4.00 meters wide; provided that all firewall construction at the side property lines shall not exceed 50% of the total perimeter of the R-3 property, i.e., total length of all property lines; provided that firewalls in R-3 lots shall only be allowed for a maximum two (2) storey structure but not at the rear property line where the maximum allowed firewall height shall only be 3.20 meters measured

vertically from established grade; and provided further that all the applicable stipulations of the Fire Code are strictly followed.

- vi. For **townhouse residential (R-4)** uses or occupancies, **firewalls on the two (2) sides of each townhouse unit may be permitted**; the R-4 firewall can be erected on a maximum of 85% of the total length of each side property line; provided that all firewall construction shall not exceed 50% of the total perimeter of each R-4 property, i.e., total length of all property lines; provided that firewalls in each R-4 use or occupancy shall be allowed for a maximum three (3) storey structure; and provided further that all the applicable stipulations of the Fire Code are strictly followed;
- vii. For **residential condominium (R-5)** uses or occupancies, **two (2) types of firewall construction may be permitted**:
 - (a) For a **R-5 use or occupancy with a firewall on two (2) sides**, a firewall can be erected on a maximum of 75% of the total length of each side property line; provided that all firewall construction at the side property lines shall not exceed 50% of the total perimeter of the R-5 property, i.e., total length of all property lines; provided that side firewalls in R-5 uses or occupancies shall only be allowed for a maximum eight (8) storey component structure, i.e., the podium; and provided further that all the applicable stipulations of the Fire Code are strictly followed; and
 - (b) For a **R-5 use or occupancy with a firewall on one (1) side and at the rear property line**, a firewall can be erected on a maximum of 65% of the total length of the side property line and on a maximum of 50% of the total length of the rear property line; provided that all firewall construction shall not exceed 60% of the total perimeter of the R-5 property, i.e., total length of all property lines; provided that the side firewalls in R-5 uses or occupancies shall only be allowed for a maximum eight (8) storey component structure and that at the rear property line, the maximum allowed firewall height shall only be 14.00 meters measured vertically from established grade; and provided further that all the applicable stipulations of the Fire Code are strictly followed.
- viii. **All existing openings on all firewalls shall be sealed completely to maintain the fire integrity of adjoining buildings/structures.**
- ix. The provision of a fully functional sprinkler system and the installation of other fire-retardant or fire suppression devices in the case of commercial, institutional and industrial buildings/structures may allow firewall construction for up to 70% of the total perimeter of the property lines provided that the prescribed setbacks, yards and courts fronting the Road Right-Of-Way (**RROW**) are first fully complied with; and provided further that all the applicable stipulations of the **Fire Code**, particularly on the number, type and locations of fire exits are strictly followed.

SECTION 705. Allowable Floor Areas

1. General. The Allowable Maximum Total Gross Floor Area (**TGFA**) of **any proposed building/structure** shall only be as allowed under this Rule.
2. TGFA Limitation. In **Table VII.1** hereafter, the percentages (%) indicated in the third (3rd) through eighth (8th) columns, but excluding the multiplier numbers 3, 5, 12, 18, and 30 (which represent the number of storeys/floors), are the percentages of the Total Lot Area (**TLA**) that may be used to initially determine the Allowable Maximum **TGFA** for a proposed building/structure.

3. Crosscheck of **TGFA** with Allowable Maximum Volume Building (**AMVB**). The Allowable Maximum **TGFA** once established must be thoroughly crosschecked with the **AMVB** to find out if the **AMVB** is not exceeded. If exceeded, the necessary adjustments on the Maximum Allowable **TGFA** must be made since the **AMVB must always prevail**.

**Table VII.1. Allowable Maximum Total Gross Floor Area (TGFA)
Based on the Allowed Percentage of Site Occupancy (PSO)
of the Total Lot Area (TLA)**

Character of Use/ Occupancy	Type of Building/ Structure	Allowable Maximum Total Gross Floor Area (TGFA)* by Type/ Location of Lot					
		Interior (or Rear) Lot and End Lot (see Fig. VIII.8. and VIII.5.14. of Rule VIII)	Inside (or Regular) Lot (see Fig. VIII.9. of Rule VIII)	Corner Lot (see Fig. VIII.10. of Rule VIII)	Through Lot (see Fig. VIII.11. of Rule VIII)	Corner-Through Lot (see Fig. VIII.12. of Rule VIII)	Corner Lot Abutting 3 or More Streets, etc. Rivers, Etc. (see Fig. VIII.13. of Rule VIII)
Residential GROUP A-I firewalls)	Residential TLA	3 (floors/storeys) (R-1) (without	3 x50% of TLA x 60% of	3 x70% of TLA	3 x70% of TLA	3 x70% of TLA	3 x70% of TLA
	Basic Residential 2 (R-2)	3 x 70%	3 x 60%	3 x 70%	3 x 70%	3 x 70%	3 x 70%
	Maximum Residential 2 (R-2)	5 x 70%	5 x 60%	5 x 70%	5 x 70%	5 x 70%	5 x 70%
	Basic Residential 3 (R-3)	3 x 70%	3 x 70%	3 x 70%	3 x 70%	3 x70%	3 x70%
	Maximum Residential 3 (R-3)	12x80%	12x80%	12x80%	12x80%	12x80%	12x80%
	Residential 4 (R-4)/ Individual Townhouse Lots/Units	3 x 80%	3 x 80%	3 x 80%	3 x 80%	3 x 80%	3 x 80%

	Residential 4 (R-4)/ Individual Townhouse Lots/Units	3 x 80%	3 x 80%	3 x 80%	3 x 80%	3 x 80%	3 x 80%
	Residential 5 (R-5)/ Condominiums	18x80%	18x80%	18x80%	18x80%	18x80%	18x80%
Residential GROUP A-I (with firewalls)	Residential 1 (R-1)	Not applicable (NA)	NA	NA	NA	NA	NA
Character of Use/ Occupancy	Type of Building/ Structure	<p style="text-align: center;">Allowable Maximum Total Gross Floor Area (TGFA)* by Type/ Location of Lot</p> <p>*Note: Building Height Limit (BHL) multiplied by the Allowable Maximum Building Footprint (AMBF) expressed as a percentage (%) of the Total Lot Area or TLA (with or without firewall). Figure subject to reduction to comply with the floor area component of the Allowable Maximum Volume of Building (AMVB). Refer to Table VII.1. to arrive at the percentage (%) of TLA.</p>					
	Basic Residential 2 (R-2)	3 x 75%	3 x 70%	3 x 75%	3 x 75%	3 x 75%	3 x 75%
	Maximum Residential 2 (R-2)	5 x 75%	5 x 70%	5 x 75%	5 x 75%	5 x 75%	5 x 75%
	Basic Residential 3 (R-3)	3 x 80%	3 x 80%	3 x 80%	3 x 80%	3 x 80%	3 x 80%
	Maximum Residential 3 (R-3)	12x80%	12x80%	12x80%	12x80%	12x80%	12x80%
	Residential 4 (R-4)/ Individual Townhouse Lots/Units	3 x 80%	3 x 80%	3 x 80%	3 x 80%	3 x 80%	3 x 80%
	Residential 5 (R-5)/ Condominiums	18x80%	18x80%	18x80%	18x80%	18x80%	18x80%
Commercial GROUPS B, C, E, H, I	Commercial 1 (Com-1)	5 x 80%	5 x 75%	5 x 80%	5 x 80%	5 x 90%	5 x 90%
	Commercial 2 (Com-2)	12x80%	12x75%	12x80%	12x80%	12x90%	12x90%

	Commercial 3 (Com-3)	30 x 80%	30x75%	30x80%	30x80%	30x90%	30x90%
	Commercial 1 (Com-1) with Sprinkler System & Firewalls	5 x 85%	5 x 85%	5 x 90%	5 x 90%	5 x 95%	5 x 95%
	Commercial 2 (Com-2) with Sprinkler System & Firewalls	12x85%	12x85%	12x90%	12x90%	12x95%	12x95%
	Commercial 3 (Com-3) with Sprinkler System & Firewalls	30x85%	30x85%	30x90%	30x90%	30x95%	30x95%

Character of Use/ Occupancy	Type of Building/ Structure	Allowable Maximum Total Gross Floor Area (TGFA)* by Type/ Location of Lot					
		*Note: Building Height Limit (BHL) multiplied by the Allowable Maximum Building Footprint (AMBF) expressed as a percentage (%) of the Total Lot Area or TLA (with or without firewall). Figure subject to reduction to comply with the floor area component of the Allowable Maximum Volume of Building (AMVB). Refer to Table VII.1. to arrive at the percentage (%) of TLA.					
Industrial GROUPS F, G	Industrial 1 (Ind-1)	Duly- approved Building Height Limit (BHL) x 80% of TLA	BHL x 75% of TLA	BHL x 80% of TLA	BHL x 80% of TLA	BHL x 90% of TLA	BHL x 90% of TLA
	Industrial 2 (Ind-2)	BHL x 80%	BHL x 75%	BHL x 80%	BHL x 80%	BHL x 90%	BHL x 90%
	Industrial 3 (Ind-3)	BHL x 80%	BHL x 75%	BHL x 80%	BHL x 80%	BHL x 90%	BHL x 90%
	Industrial 1 (Ind-1) with Sprinkler System & Firewalls	BHL x 85%	BHL x 85%	BHL x 90%	BHL x 90%	BHL x 95%	BHL x 95%
	Industrial 2 (I-2) with Sprinkler System & Firewalls	BHL x 85%	BHL x 85%	BHL x 90%	BHL x 90%	BHL x 95%	BHL x 95%
	Industrial 3 (Ind-3) with Sprinkler System & Firewalls	BHL x 85%	BHL x 85%	BHL x 90%	BHL x 90%	BHL x 95%	BHL x 95%
	Institutional GROUP D	Without Sprinkler System & Firewalls	BHL x 50% of TLA	BHL x 50% of TLA	BHL x 60% of TLA	BHL x 60% of TLA	BHL x 60% of TLA
	With Sprinkler System & Firewalls	BHL x 60% of TLA	BHL x 60% of TLA	BHL x 70% of TLA	BHL x 70% of TLA	BHL x 70% of TLA	BHL x 70% of TLA

Cultural	Without Sprinkler System & Firewalls	BHL x 60% of TLA	BHL x 60% of TLA	BHL x 65% of TLA	BHL x 65% of TLA	BHL x 65% of TLA	BHL x 65% of TLA
	With Sprinkler System & Firewalls	BHL x 70%	BHL x 70%	BHL x 70%	BHL x 70%	BHL x 70%	BHL x 70%
Transportation	Without Sprinkler System & Firewalls	BHL x 50% of TLA	BHL x 50% of TLA	BHL x 60% of TLA	BHL x 60% of TLA	BHL x 60% of TLA	BHL x 60% of TLA
	With Sprinkler System & Firewalls	BHL x 60%	BHL x 60%	BHL x 70%	BHL x 70%	BHL x 70%	BHL x 70%

Note:

Maximum of sixty (60) storeys (180.00 meters) **BHL** for inland areas not close to airports.

SECTION 706. Allowable Floor Area Increases

The floor areas hereinabove provided may be increased in certain specific instances and under appropriate conditions, based on the existence of public space, streets or yards extending along and adjoining two or more sides of the building or structure subject to the approval of the **Building Official**. (Refer to **Guidelines** on Determining Gross Floor Area and Total Gross Floor Area of a Building/Structure at the end of this Rule)

SECTION 707. Maximum Height of Buildings

1. The maximum height and number of storeys of **proposed building** shall be dependent upon the character of use or occupancy and the type of construction, considering end-user population density, light and ventilation, width of **RROW**/streets particularly of its roadway/carrageway component, building bulk, off-street cum off-site parking requirements, etc. and in relation to local land use plan and zoning regulations as well as other environmental considerations, e.g., geological, hydrological, meteorological, topographical, prevailing traffic conditions, the availability and capacity of public utility/service systems, etc. (Refer to **Guidelines** on Building Bulk at the end of this Rule)
2. Determination of **Building Height**:
 - a. **BUILDING HEIGHT LIMIT (BHL)** - the **maximum height** to be allowed for **buildings/structures** based on their proposed use or occupancy; the **BHL** is generally determined after the application of other **development controls (DC)** and certain other parameters, i.e., considerations of site conditions, view, etc. (**Table VII.2.** of this Rule). The **BHL** shall be generally measured from the established grade line to the topmost portion of the proposed building/structure. If applicable, the **BHL** may be subject to clearance requirements of the Air Transportation Office (**ATO**) or of the concerned military/security authorities. (Refer to **Guidelines** on Development Controls at the end this Rule)

BHL excludes the height of permitted/allowed projections above the roof of the **building/structure**, e.g., signage, mast, antenna, telecom tower, beacons and the like.

- b. The Building Height Limit (**BHL**) of any **proposed building**/structure shall only be as allowed under this Rule (as shown in table below) or under the duly approved city/municipal (local) zoning ordinance, whichever is more restrictive.

Table VII.2. Building Height Limit (BHL) by Type of Use or Occupancy

Character of Use or Occupancy	Type of Building/ Structure	Building Height Limit (BHL)	
		Number of allowable storeys/floors above established grade	Meters above highest grade
1. Residential	Residential 1 (R-1)	3	10.00
	Residential 2 (R-2)		
	a. Basic	3	10.00
	b. Maximum	5	15.00
	Residential 3 (R-3)		
	a. Basic	3	10.00
b. Maximum	12	36.00	
	Residential 4 (R-4)/ Townhouses (Individual lots/ units)	3	10.00
	Residential 5 (R-5)/ Condominiums	12 - 18	36.00 - 54.00
2. Commercial	Commercial 1 (C-1)	3 - 5	10.00 -15.00
	Commercial 2 (C-2)	6	18.00
	Commercial 3 (C-3)	16-60	48.00 -180.00
Character of Use or Occupancy	Type of Building/ Structure	Building Height Limit (BHL)	
		Number of allowable storeys/floors above established grade	Meters above highest grade
3. Industrial	Industrial 1 (I-1)	15.00 meters but not exceed the duly-approved BHL in the major zone it is part of	
	Industrial 2 (I-2)	21.00 meters but not exceed the duly-approved BHL in the major zone it is part of	
	Industrial 3 (I-3)	27.00 meters but not exceed the duly-approved BHL in the major zone it is part of)	
4. Institutional	-	15.00 meters (or must follow the duly-approved BHL in the major zone it is part of)	
5. Cultural	-	30.00 meters (or must follow the duly-approved BHL in the major zone it is part of)	
6. Utility/Transportation/RROW/ Services	-	15.00 meters (or must complement the duly-approved BHL in the major zone it is part of)	

7. Parks and Open Recreational and Entertainment Spaces	-	15.00 meters (or must complement the duly-approved BHL in the major zone it is part of)	
8. Agricultural/Agro-Industrial/Tourism	-	15.00 meters (or must complement the duly-approved BHL in the major zone it is part of)	
9. Planned Unit Development (PUD)	PUD at a reclamation area close to an operating airport	3 - 15	10.00-45.00 (with ATO-prescribed BHL as needed)
	PUD at a reclamation area	3 - 30	10.00 - 30.00
	PUD at a coastal area	16 - 45	48.00 - 135.00
	PUD at an inland area close to an operating airport	3 - 25	10.00 - 75.00 (with ATO-prescribed BHL as needed)
	PUD at an inland area	12 - 60	36.00 - 180.00

Notes:

a. *Establishing Grade*

- *In case of sloping grade where the edges of the building footprint (**AMBF**) running perpendicular to the **RROW** has a difference in elevation of less than 3.00 meters, the highest adjoining natural grade (ground surface) or finished grade (sidewalk surface) shall be considered the established grade elevation (**Figure VII.1.**);*
- *In case of sloping grade where the edges of the building footprint (**AMBF**) running perpendicular to the **RROW** has a difference in elevation of more than 3.00 meters, the average grade level of the building footprint (**AMBF**) shall be considered the established grade elevation (see **Figure VII.3.**); and*
- *The **building**/structure height shall be measured from the highest adjoining public sidewalk (finished grade) or ground surface (natural grade); Provided, that the height measured from the lowest adjoining surface shall not exceed such maximum height by more than 3.00 meters; Except, that towers, spires and steeples, erected as parts of the building and not used for habitation or storage are limited as to the height only by structural design, if completely of incombustible materials, or may extend but not exceed 6.00 meters above the prescribed building height limit (**BHL**) for each occupancy group, if of combustible materials (**Figures VII.2.**).*

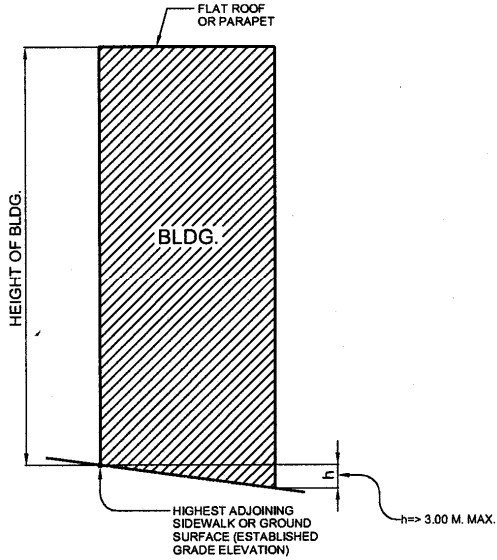

Figure VII.1.

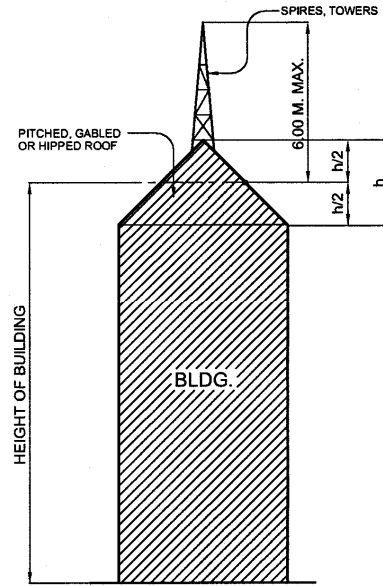

Figure VII.2.

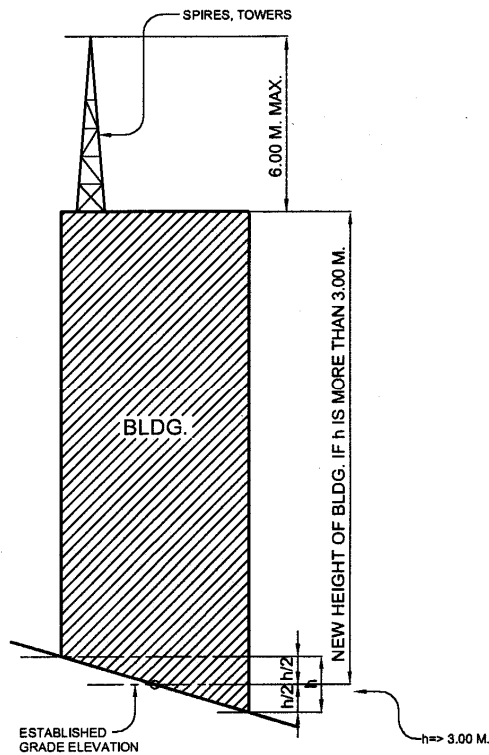

Figure VII.3.

HEIGHT OF BUILDING / STRUCTURE

Annotation. The height of buildings should also be generally proportional to its base/footprint. In practice, a smaller footprint cum taller profile for a building is resorted to in order to preserve as much of the open space within a lot (or surrounding the building) as much as possible.

3. Other Considerations in Height Determination

- a. In any given locality, the height of proposed **buildings/structures** shall be governed by the following factors:
 - i. The **designer/space planner** must consider both the present and projected population density within the project site and in the project's location/area at full completion/operation of the project;
 - ii. For a given **volume of building/structure** (the **building bulk**), that which has a lesser Percentage of Site Occupancy (**PSO**) or area of ground coverage Allowable Maximum Building Footprint (**AMBF**) or Maximum Allowable Construction Area (**MACA**) may be built higher than that with a greater **PSO, AMBF or MACA**;
 - iii. A proposed building/structure which has a greater **TGFA** requirement shall be built higher than that with a lower **TGFA** requirement;
 - iv. A proposed building/structure on a lot with a higher **FLAR designation/rights** may be built higher than that on a lot with a lower **FLAR designation/rights**; and
 - v. Lots that face a wider **RROW** and therefore with more **RROW** features/elements may become the site of a taller building/structure as compared to a lot facing a narrow **RROW**.
- b. The height of proposed buildings/structures shall also be governed by the following **RROW**-based limitations:
 - i. If only one (1) **RROW** services a lot and such is only 6.00 to 7.00 meters wide, a **BHL** of three (3) storeys (or 9.00 meters maximum) shall be observed regardless of use or occupancy, lot size, lot dimensions, lot frontage and like considerations.
 - ii. If only one (1) **RROW** services a lot and such is only 4.00 to 5.00 meters wide, a **BHL** equivalent to 2 ½ storeys (or 7.50 meters maximum) shall be observed regardless of use or occupancy, lot size, lot dimensions, lot frontage and like considerations. If only one (1) **RROW** services a lot and such is only 3.00 meters wide or less, a **BHL** equivalent to two (2) storeys (or 6.00 meters maximum) shall be observed regardless of use or occupancy, lot size, lot dimensions, lot frontage and like considerations.
 - iii. Taller buildings are allowed for duly approved high-density developments such as Planned Unit Development (**PUD**) areas. Taller and bulkier buildings are better suited in such areas due to higher end-user targets, more advanced and coordinated planning efforts and the application of more stringent **development controls (DC)** by the project proponents themselves.
- c. The following factors shall also be considered in the determination of the building height:
 - i. Soil characteristics, lot location in relation to fault lines and earthquake belts or proximity to volcanoes and other geological conditions.
 - ii. Hydrological conditions such as the water table at the site and distance to waterways and shorelines.
 - iii. Meteorological conditions such as the frequency and intensity of destructive typhoons/monsoon winds/rains, prevailing wind speed and direction, relative humidity, amount of precipitation and the prevailing ambient conditions.

- iv. Effect/s of environmental conditions on the building/structure and vice versa coupled with the effective control of air, noise and thermal pollution, radiant heat, lights and shadows, etc., and the optimization of natural light and ventilation.
 - v. Effect/s of traffic conditions on the building/structure and vice versa and the satisfaction of parking/loading requirements in accordance with this Rule.
 - vi. Availability and capacity of public utility/service system considering the availability and adequacy of electric power, potable and non-potable water supply, drainage and sewerage, transportation and communications facilities, solid waste management system, etc.
 - vii. Need for applicable building safety and maintenance systems, e.g., lightning arresters, beacons, protective railings and barriers, gondolas, window washing systems, etc.
- d. In accordance with the Standards and Recommended Practices (**SARP**) of the International Civil Aviation Organization (**ICAO**) where the Philippines is a member state and of **Administrative Order No. 5 (Civil Air Regulation)** of the Air Transportation Office (**ATO**), the following rules and regulations shall govern the construction of buildings/structures within the 24.00 kilometer radius of aerodromes where turbo-jet aircraft operate and within the 10.00 kilometer radius of aerodromes where no turbo-jet aircraft operate. (**Figs. VII.4.** through **VII.8.**)
- i. The height of buildings/structures within this area shall be limited by an imaginary line with slope of 2% or 1:50 for aerodromes where turbo-jet aircraft operate and 2.5% or 1:40 for aerodromes where no turbo-jet aircraft operate from the inner edge reckoned from the surface of the runway. The dimensions of the isosceles trapezoidal are as shown on **Table VII.3.** hereafter.

Table VII.3. Dimensions of Isosceles Trapezoid

Type of Aerodrome	Inner Edge (Start Base) (meters)	Long Base (meters)	Distance Between Bases (meters)
Aerodromes where turbo-jet aircraft operates	300	4,800	15,000
	150	4,650	15,000
Aerodromes where no turbo-jet aircraft operates	150	2,150	10,000
	100	2,100	10,000

- ii. No new buildings/structures shall be allowed within the runway strip.
- iii. A height clearance certificate shall be first secured from the Air Transportation Office (**ATO**) before a building permit may be issued for the construction of buildings/structures located:
 - (a) Within 4.00 kilometer radius of the runway ends of an aerodrome regardless of height;
 - (b) From 4.00 kilometer to 24.00 kilometer radius of the runway ends of an aerodrome where turbo-jet aircraft operate and exceeding 45.00 meters in height above the elevation of the runway; and
 - (c) From 4.00 kilometer to 10.00 kilometer radius of the runway ends of an aerodrome where no turbo-jet aircraft operate and exceeding 45.00 meters in height above the elevation of the runway.

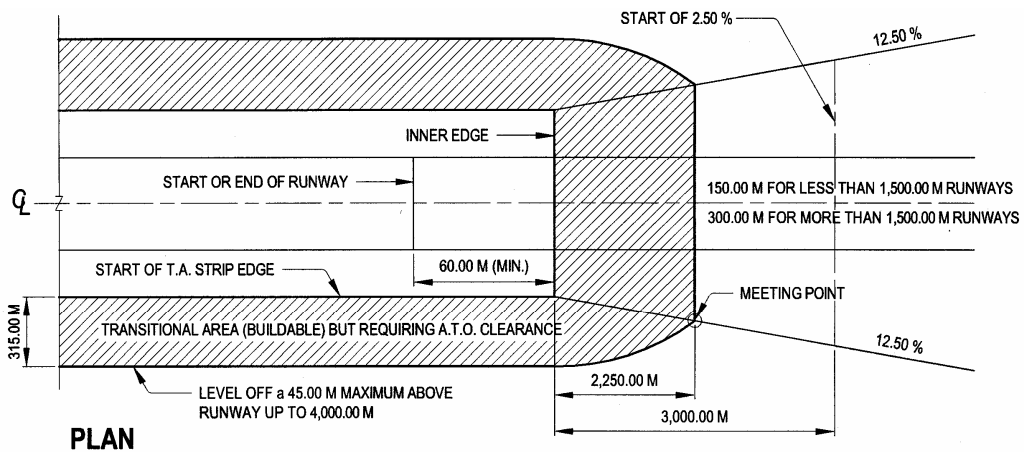

Figure VII.4.
APPROACH / DEPARTURE SURFACE

Annotation. Plan adjustments are necessary for airports with parallel runways and for runways with taxiways.

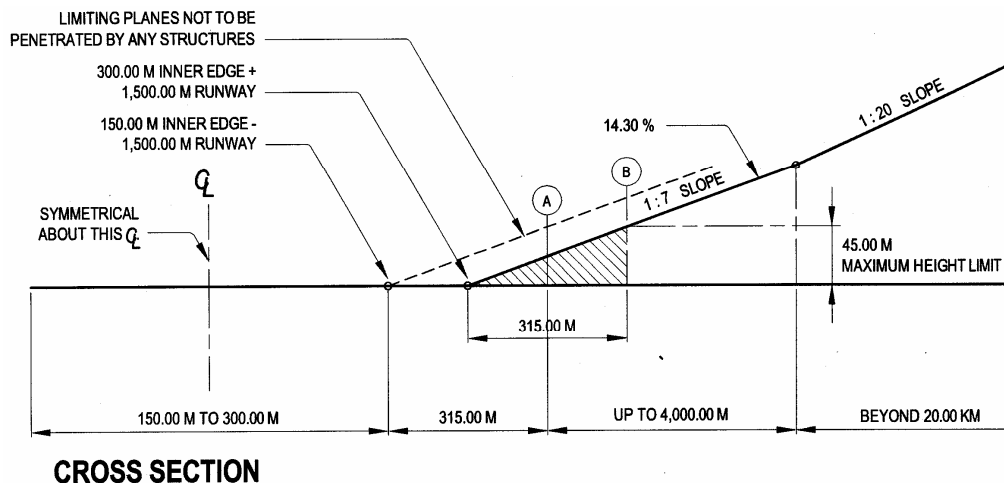

Figure VII.5.

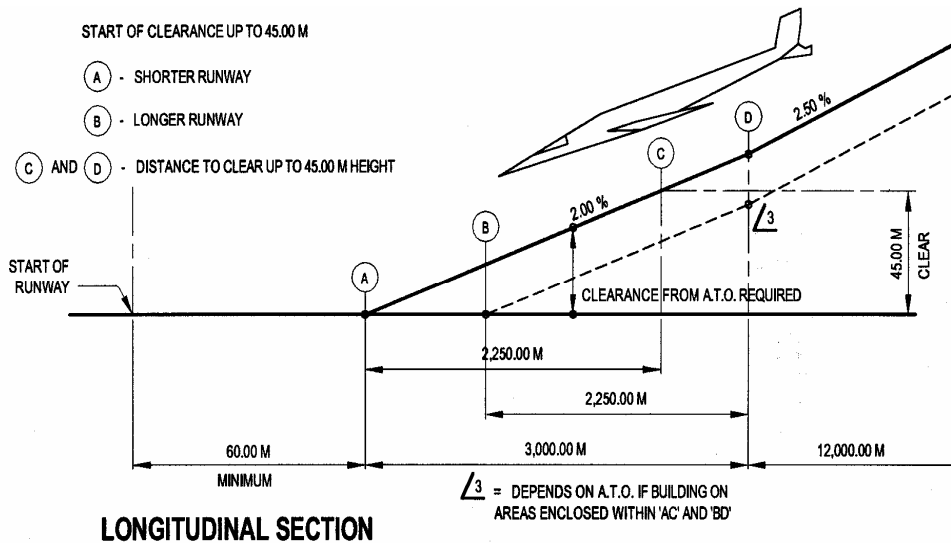

Figure VII.6.
APPROACH / DEPARTURE SURFACE

Annotation. Section adjustments may still be necessary for airports with parallel runways and for runways with taxiways.

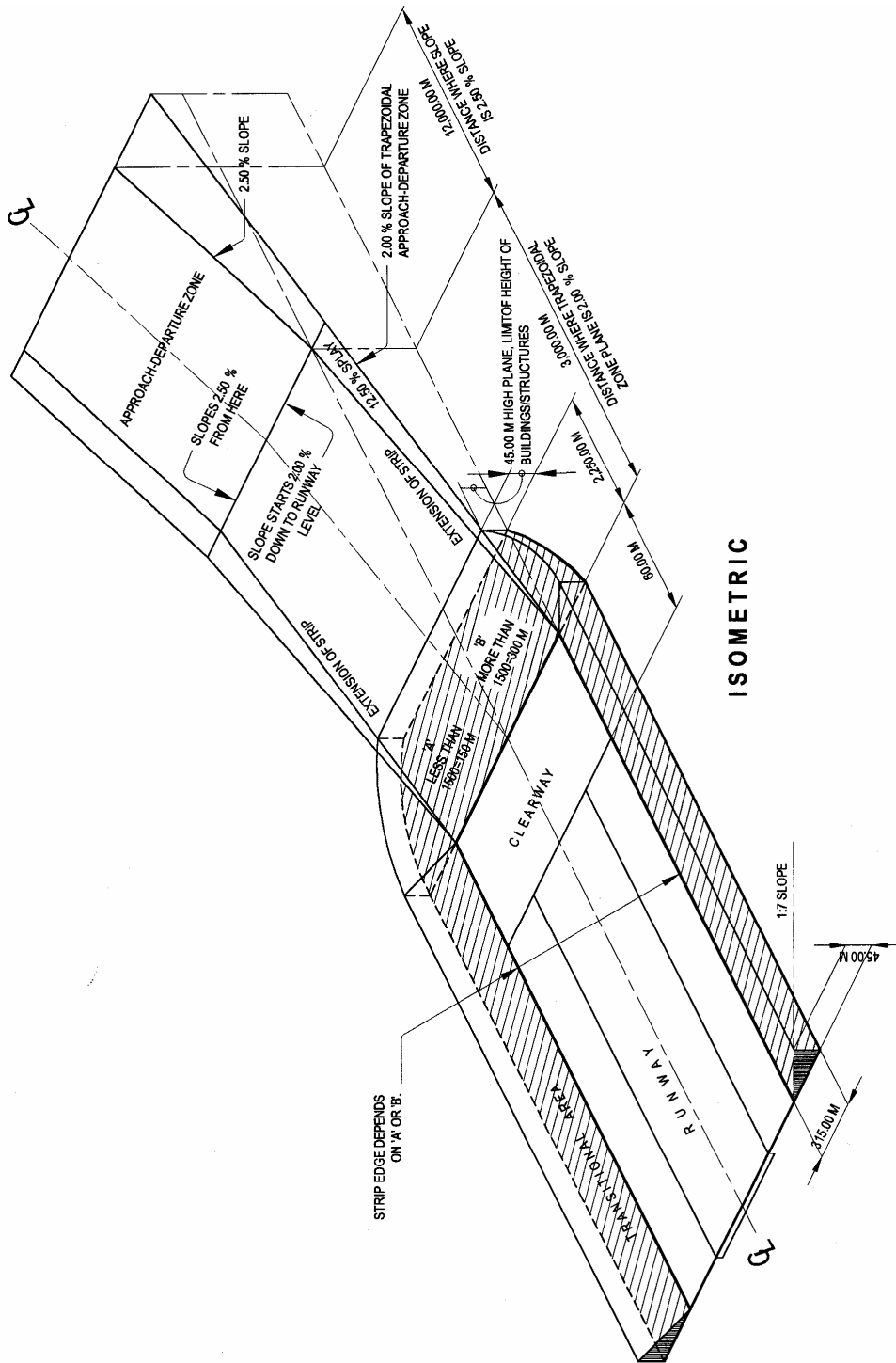
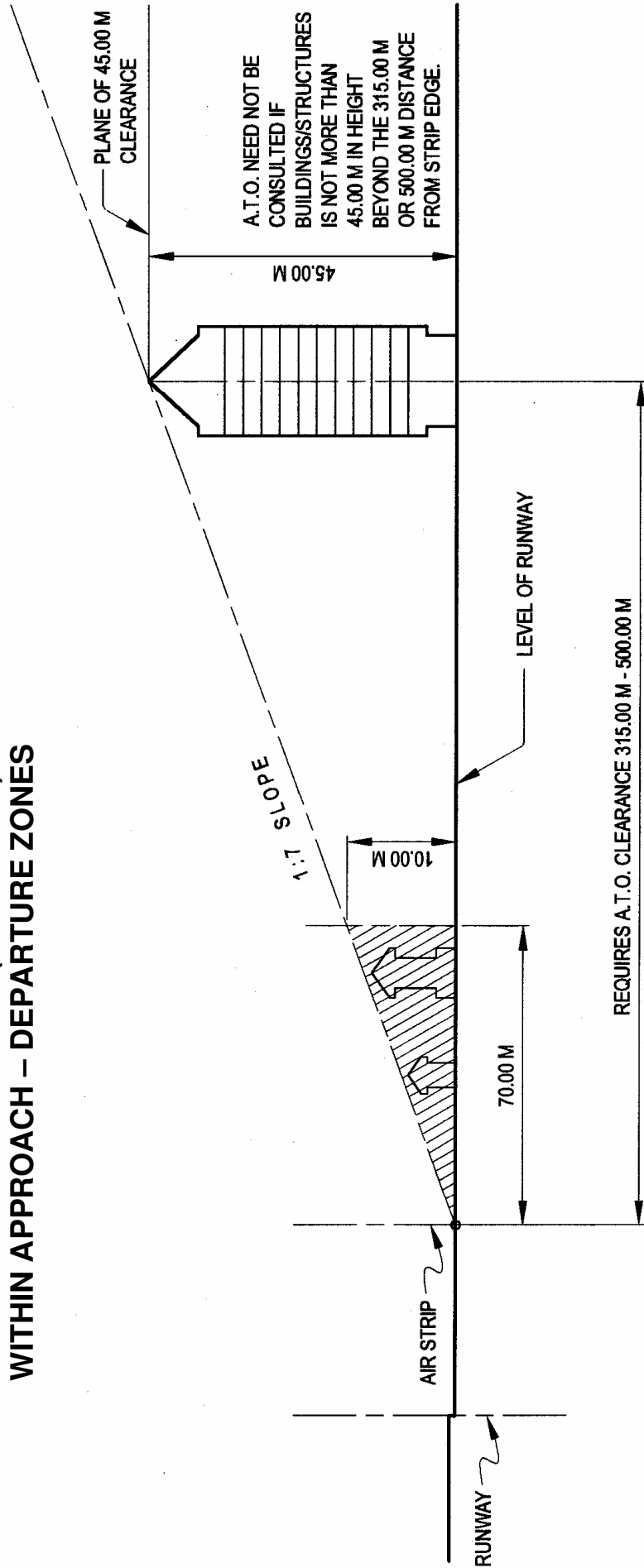

Figure VII.7.
ALLOWABLE CONDITIONS (BUILDABLE)
WITHIN APPROACH-DEPARTURE ZONES

Annotation. Isometric, plan and section adjustments may still be necessary for airports with parallel runways and for runways with taxiways.

**ALLOWABLE CONDITIONS (BUILDABLE)
WITHIN APPROACH – DEPARTURE ZONES**



CROSS SECTION

Figure VII.8.

Annotation. Adjustments may still be necessary for airports with parallel runways and for runways with taxiways.

4. **Parking Slot, Parking Area and Loading/Unloading Space Requirements**

- a. The parking slot, parking area and loading/unloading space requirements listed hereafter are generally the minimum off-street cum on-site requirements for specific uses/occupancies for buildings/structures, i.e., all to be located outside of the road right-of-way (**RROW**).
- b. The size of an **average** automobile (car) parking slot must be computed at 2.50 meters by 5.00 meters for perpendicular or diagonal parking and at 2.15 meters by 6.00 meters for parallel parking. A standard truck or bus parking/loading slot must be computed at a minimum of 3.60 meters by 12.00 meters. An articulated truck slot must be computed at a minimum of 3.60 meters by 18.00 meters which should be sufficient to accommodate a 12.00 meters container van or bulk carrier and a long/hooded prime mover. A *jeepney* or shuttle parking/loading/unloading slot must be computed at a minimum of 3.00 meters by 9.00 meters. The parking slots shall be drawn to scale and the total number of which shall be indicated on the plans and specified whether or not parking accommodations are attendant-managed.
- c. The parking space ratings listed below are minimum off-street/**off-RROW** cum on-site requirements for specific uses/occupancies for buildings/structures, i.e., all to be located outside of the road right-of-way (**RROW**):

Table VII.4. Minimum Required Off-Street (Off-RROW) cum On-Site Parking Slot, Parking Area and Loading/Unloading Space Requirements by Allowed Use or Occupancy

Specific Uses or of Occupancy (refer to Section 701 of this Rule)	Reference Uses or Character of Occupancies or Type of Buildings/Structures	Minimum Required Parking Slot, Parking Area and Loading Space Requirements
1. GROUP A		
1.1. Division A-1	Single family and multi-family dwelling units [whether single-detached (R-1), single-attached or duplex (R-2) or rowhouse (R-3)], each privately owned or lots with dwelling units located in residential subdivisions/developments regardless of number of hectares/dwelling units	Units with a lot measuring 32.00 to 72.00 sq. meters and/or with a dwelling unit having a gross floor area of from 18.00 to 22.00 sq. meters - a minimum of one (1) pooled off-street cum on-site parking slot* for every six (6) lots or lots with dwelling units;
		Units with a lot measuring 50.00 to 96.00 sq. meters and/or with a dwelling unit having a gross floor area of from 30.00 to 42.00 sq. meters - a minimum of one (1) pooled off-street cum on-site parking slot* for every four (4) lots or lots with dwelling units;
	<i>Note:</i> * <i>The parking slot requirements shall be an integral part of buildings/structures and any parking slot provided outside the building/structure will be quantified only as buffer parking.</i>	

Specific Uses or of Occupancy (refer to Section 701 of this Rule)	Reference Uses or Character of Occupancies or Type of Buildings/Structures	Minimum Required Parking Slot, Parking Area and Loading Space Requirements
		Unit with a lot measuring 100.00 to 120.00 sq. meters and/or with a dwelling unit having a minimum gross floor area of from 30.00 to 42.00 sq. meters - a minimum of one (1) off-street cum on-site parking slot* for each lot or lot with dwelling unit;
		Unit with a lot measuring more than 120.00 sq. meters and/or with a dwelling unit having a minimum gross floor area of more than 42.00 sq. meters - minimum of one (1) off-street cum on site parking slot* for each lot or lot with dwelling unit;
	Units located in townhouse (R-4) buildings/structures regardless of number of storeys	Units with a gross floor area of 50.00 sq. meters - provide one (1) pooled parking slot* for every two (2) units or fraction thereof, i.e., with more than two (2) but not less than four (4) units;
		Unit with a gross floor area above 50.00 up to 150.00 sq. meters - provide one (1) parking slot* for each unit;
		Unit with a gross floor area above 150.00 sq. meters - provide two (2) parking slots* for each unit.
	Indigenous family dwelling units; each privately owned	At least one (1) car parking slot* for every six (6) dwelling units and which shall be provided outside of the RROW (within property or lot lines only)
	<p>Note:</p> <p>* The parking slot requirements shall be an integral part of buildings/structures and any parking slot provided outside the building/structure will be quantified only as buffer parking.</p> <p>**The following prohibitions on parking slots:</p> <ol style="list-style-type: none"> 1. Conversion/change of use/occupancy. 2. Reduction of parking spaces. 3. Encroachment on RROW. 4. Public utility and bulky vehicles. 	

Specific Uses or of Occupancy (refer to Section 701 of this Rule)	Reference Uses or Character of Occupancies or Type of Buildings/Structures	Minimum Required Parking Slot, Parking Area and Loading Space Requirements
1.2. Division A-2	Multi-family dwelling units located in residential condominium (R-5) buildings/structures regardless of number of storeys	Units with a gross floor area of from 18.00 to 22.00 sq. meters - provide one (1) pooled parking slot* for every eight (8) units or for a fraction thereof, e.g., another slot* shall be provided if there are more than eight (8) units but less than sixteen (16) units, etc.;
		Units with a gross floor area up to 50.00 sq. meters - provide one (1) pooled parking slot* for every six (6) medium cost units or for a fraction thereof, e.g., another slot* shall be provided if there are more than six (6) but less than twelve (12) medium cost units, etc., or provide one (1) parking slot* for each open market unit (as defined under the revised IRR of PD 957);
		Units with a gross floor area above 50.00 sq. meters up to 100.00 sq. meters - provide one (1) pooled parking slot* for every four (4) medium cost units, or provide one (1) parking slot* for each open market unit (as defined under the revised IRR of PD 957); and
		Units with a gross floor area of more than 100.00 sq. meters - one (1) parking slot* for each unit.
2. GROUP B		
2.1. Division B-1	Hotels	One (1) car parking slot for every three (3) rooms or a fraction thereof for highly urbanized areas and one (1) car parking slot for every seven (7) rooms or a fraction thereof for all other areas; and two (2) tourist bus parking slots for each hotel; provide at least one (1) loading slot for articulated truck or vehicle
<p>Note: *The parking slot requirements shall be an integral part of buildings/structures and any parking slot provided outside the building/structure will be quantified only as buffer parking.</p>		

Specific Uses or of Occupancy (refer to Section 701 of this Rule)	Reference Uses or Character of Occupancies or Type of Buildings/Structures	Minimum Required Parking Slot, Parking Area and Loading Space Requirements
		A 12.00 meters long container van plus 4.00 meter length for the prime mover and one (1) loading slot for a standard truck for every 5,000.00 sq. meters of gross floor area (GFA); and provide truck maneuvering area outside of the RROW (within property or lot lines only)
	Residential hotels and apartels	One (1) car slot for every five (5) units or a fraction thereof; and one (1) bus parking slot for every sixty (60) rooms/units or a fraction thereof
	Motels	One (1) car slot for every unit
	Pension/boarding/lodging houses	One (1) car slot for every twenty (20) beds
3. GROUP C		
3.1. Division C-1	Bowling alleys	One (1) car slot for every four (4) alleys
3.2. Division C-2	Churches and similar places of worship	One (1) car slot and one (1) jeepney/shuttle slot for every 50.00 sq. meters of congregation area
	Public elementary, secondary, vocational and trade school (GI)	One (1) off-street cum on-site parking slot for every ten (10) classrooms; and one (1) off-RROW (or off-street) passenger loading space that can accommodate two (2) queued jeepney/shuttle slots
	Private elementary, secondary, vocational and trade school (GI)	One (1) car slot for every five (5) classrooms; one (1) off-RROW (or off-street) passenger loading space that can accommodate two (2) queued jeepney/shuttle slots; and one (1) school bus slot for every one hundred (100) students
	<p>Note:</p> <p>* The parking slot requirements shall be an integral part of buildings/structures and any parking slot provided outside the building/structure will be quantified only as buffer parking.</p> <p>** The following prohibitions on parking slots:</p> <ol style="list-style-type: none"> 1. Conversion/change of use/occupancy. 2. Reduction of parking spaces. 3. Encroachment on RROW. 4. Public utility and bulky vehicles. 	

Specific Uses or of Occupancy (refer to Section 701 of this Rule)	Reference Uses or Character of Occupancies or Type of Buildings/Structures	Minimum Required Parking Slot, Parking Area and Loading Space Requirements
	Public colleges and universities (GI)	One (1) car slot for every five (5) classrooms; one (1) off-RROW (or off-street) passenger loading space that can accommodate two (2) queued <i>jeepney</i> /shuttle slots; and one (1) school bus slot for every two hundred (200) students
	Private colleges and universities (GI)	One (1) car slot for every three (3) classrooms; one (1) off-RROW (or off-street) passenger loading space that can accommodate two (2) queued <i>jeepney</i> /shuttle slots; and one (1) school bus slot for every one hundred (100) students
4. GROUP D		
4.1. Division D-1	Mental hospitals, sanitarium and mental asylums and like uses	One (1) off-street cum on-site car parking slot for every twenty five (25) beds; and one (1) off-RROW (or off-street) passenger loading space that can accommodate two (2) queued <i>jeepney</i> /shuttle slots
4.2. Division D-2	Public hospital	One (1) off-street cum on-site car parking slot for every twenty five (25) beds; and one (1) off-RROW (or off-street) passenger loading space that can accommodate two (2) queued <i>jeepney</i> /shuttle slots; provide at least one (1) loading slot for articulated truck or vehicle (a 12.00 meter long container van plus 6.00 meter length for a long/hooded prime mover) and one (1) loading slot for a standard truck for every 5,000.00 sq. meters of gross floor area (GFA); and provide truck maneuvering area outside of the RROW (within property or lot lines only)
<p><i>Note:</i></p> <p>* <i>The parking slot requirements shall be an integral part of buildings/structures and any parking slot provided outside the building/structure will be quantified only as buffer parking.</i></p> <p>**<i>The following prohibitions on parking slots:</i></p> <ol style="list-style-type: none"> 1. <i>Conversion/change of use/occupancy.</i> 2. <i>Reduction of parking spaces.</i> 3. <i>Encroachment on RROW.</i> 4. <i>Public utility and bulky vehicles.</i> 		

Specific Uses or of Occupancy (refer to Section 1.3 of this Rule)	Reference Uses or Character of Occupancies or Type of Buildings/Structures	Minimum Required Parking Slot, Parking Area and Loading Space Requirements
	Private hospital	One (1) off-street cum on-site car parking slot for every twelve (12) beds; and one (1) off-RROW (or off-street) passenger loading space that can accommodate two (2) queued jeepney/shuttle slots; provide at least one (1) loading slot for articulated truck or vehicle (a 12.00 meters long container van plus 6.00 meters length for a long/hooded prime mover) and one (1) loading slot for a standard truck for every 5,000.00 sq. meters of GFA ; and provide truck maneuvering area outside of the RROW (within property or lot lines only)
4.3. Division D-3	Nursing homes for ambulatory patients, school and home, for children over kindergarten age, orphanages and the like	One (1) off-street cum on-site car parking slot for every twelve (12) beds; and one (1) off-RROW (or off-street) passenger loading space that can accommodate two (2) queued jeepney/shuttle slots
5. GROUP E		
5.1. Division E-1	Terminals, Inter-modals or Multi-modals, Depots and the like (UTS)	One (1) car slot for every 500.00 sq. meters of gross floor area or for a fraction thereof; and one (1) off-RROW (or off-street) passenger loading space that can accommodate two (2) queued jeepney/shuttle slots or two (2) queued bus slots whichever is applicable; maneuvering area of buses, trucks and like vehicles shall be outside of the RROW (within property or lot lines only)
<p>Note:</p> <p>* <i>The parking slot requirements shall be an integral part of buildings/structures and any parking slot provided outside the building/structure will be quantified only as buffer parking.</i></p>		

Specific Uses or of Occupancy (refer to Section 1.3 of this Rule)	Reference Uses or Character of Occupancies or Type of Buildings/Structures	Minimum Required Parking Slot, Parking Area and Loading Space Requirements
	Transit Stations and the like (UTS)	Provide on each side of the RROW one (1) off-RROW (or off-street) passenger loading space that can accommodate four (4) queued <i>jeepney</i> /shuttle slots or three (3) queued bus slots whichever is applicable; in case of elevated mass transit stations, on-roadway terminals or on-RROW terminals on both sides of the RROW may be considered
		One (1) car slot for every 100.00 sq. meters of shopping floor area
5.2. Division E-2	Neighborhood shopping center/supermarket (C-1)	One (1) customer (buyer) <i>jeepney</i> /shuttle parking slot for every 150.00 sq. meters of wet and dry market floor area and one (1) vendor (seller) <i>jeepney</i> /shuttle parking slot or loading space for every 300.00 sq. meters of wet and dry market floor area; and one (1) off-RROW (off-street) terminal that can accommodate at least two (2) <i>jeepneys</i> and six (6) tricycles for every 1,000.00 sq. meters of wet and dry market floor area
	Public Markets (C)	One (1) car slot for every 30.00 sq. meters of customer area
	Restaurants, fast-food centers, bars and beerhouses (C)	One (1) car slot for every 20 sq. meters of customer area; and two (2) tourist parking slots for tourist bus parking slots for each theater-restaurant
	Nightclubs, super clubs and theater-restaurants (C)	One (1) car slot for every 30.00 sq. meters of customer area
	<p>Note:</p> <p>* <i>The parking slot requirements shall be an integral part of buildings/structures and any parking slot provided outside the building/structure will be quantified only as buffer parking.</i></p>	

Specific Uses or of Occupancy (refer to Section 1.3 of this Rule)	Reference Uses or Character of Occupancies or Type of Buildings/Structures	Minimum Required Parking Slot, Parking Area and Loading Space Requirements
	Nightclubs, super clubs and theater-restaurants (C)	Units with a gross floor area of from 18. 00 to 40. 00 sq. meters – provide one (1) pooled parking slot* for every two (2) units or for a fraction thereof.
	Units located in office, commercial or mixed-use condominium buildings/ structures regardless of number of storeys	Unit with a gross floor area of from 41. 00 to 70. 00 sq. meters –provide one (1) parking slot* for each unit; and Unit with a gross floor area of more than 70.00 sq. meters provide one (1) parking slot* for every 70.00 sq. meters and for a fraction thereof;
	Columbarium	One (1) car slot for every compartment niche
5.3. Division E-3	Aircraft hangars, open parking carports and garages, etc.	One (1) car slot for every 1,000.00 sq. meters of gross floor area and one (1) bus slot for every one hundred (100) workers; if number of workers exceed two hundred (200), provide one (1) off-RROW (or off-street) passenger loading space that can accommodate two (2) queued <i>jeepney/shuttle</i> slots
6. GROUP F		
6.1. Division F-1	Industrial buildings, mills, breweries, etc. (I)	One (1) car slot for every 1,000.00 sq. meters of gross floor area and one (1) bus slot for every one hundred (100) workers; if number of workers exceed two hundred (200), provide one (1) off-RROW (or off-street) passenger loading space that can accommodate two (2) queued <i>jeepney/shuttle</i> slots; provide at least one (1) loading slot for
<p>Note:</p> <p>* <i>The parking slot requirements shall be an integral part of buildings/structures and any parking slot provided outside the building/structure will be quantified only as buffer parking.</i></p>		

Specific Uses or of Occupancy (refer to Section 1.3 of this Rule)	Reference Uses or Character of Occupancies or Type of Buildings/Structures	Minimum Required Parking Slot, Parking Area and Loading Space Requirements
		truck or vehicle (a 12.00 meter long container van plus 6.00 meters length for a long/hooded prime mover) and one (1) loading slot for a standard truck for every 5,000.00 sq. meters of GFA; and provide truck maneuvering area outside of the RROW (within property or lot lines only)
7. GROUP G		
7.1. Division G-1	Industrial buildings, factories, manufacturing establishments, mercantile buildings, warehouses, storage bins, power and water generation/distribution facilities	One (1) car slot for every 1,000.00 sq. meters of gross floor area and one (1) bus slot for every one hundred (100) workers; if number of workers exceed two hundred (200), provide one (1) off-RROW (or off-street) passenger loading space that can accommodate two (2) queued jeepney/shuttle slots; provide at least one (1) loading slot for articulated truck or vehicle (a 12.00 meter long container van plus 6.00 meters length for a long/ hooded prime mover) and one (1) loading slot for a standard truck for every 5,000.00 sq. meters of GFA; and provide truck maneuvering area outside of the RROW (within property or lot lines only)
7.2. Division G-2	-do-	-do-
7.3. Division G-3	-do-	-do-
7.4. Division G-4	-do-	-do-
7.5. Division G-5	-do-	-do-
	<p>Note:</p> <p>* The parking slot requirements shall be an integral part of buildings/structures and any parking slot provided outside the building/structure will be quantified only as buffer parking.</p> <p>**The following prohibitions on parking slots:</p> <ol style="list-style-type: none"> 1. Conversion/change of use/occupancy. 2. Reduction of parking spaces. 3. Encroachment on RROW. 4. Public utility and bulky vehicles. 	

Specific Uses or of Occupancy (refer to Section 1.3 of this Rule)	Reference Uses or Character of Occupancies or Type of Buildings /Structures	Minimum Required Parking Slot, Parking Area and Loading Space Requirements
8. GROUP H		
8.1. Division H-1	Public recreational assembly buildings such as theaters/cinemas, auditoria, etc.	One (1) car slot and one (1) <i>jeepney</i> /shuttle slot for every 50.00 sq. meters of spectator area; and one (1) bus parking slot for every two hundred (200) spectators
8.2 Division H-2	Dance halls, cabarets, ballrooms, skating rinks and cockfighting arenas, etc.	-do-
8.3 Division H-3	Dance halls, ballrooms, skating rinks, etc.	-do-
8.4 Division H-4	Covered amusement parks, amusement and entertainment complexes, etc.	one (1) car slot for every 50.00 sq. meters of gross floor area
	Clubhouses, beach houses and the like	one (1) slot for every 100.00 sq. meters of gross floor area
9. GROUP I		
9.1. Division I-1	Recreational or similar public assembly buildings such as stadia, sports complexes, convention centers, etc.	One (1) car slot and one (1) <i>jeepney</i> /shuttle slot for every 50.00 sq. meters of spectator area; and one (1) bus parking slot for every two hundred (200) spectators.
10. GROUP J		
10.1. Division J-1	Agriculture-related uses or occupancies (A)	Not required if located outside urbanized area; if located within urbanized area, provide one (1) car slot for every 1,000.00 sq. meters of gross floor area and one (1) bus slot for every one hundred (100) workers; if number of workers exceed two hundred (200), provide one (1) off-RROW (or off-street) passenger loading space that can accommodate two (2) queued <i>jeepney</i> /shuttle slots; provide at least one (1) loading slot for articulated truck or vehicle
	<p><i>Note:</i></p> <p>* <i>The parking slot requirements shall be an integral part of buildings/structures and any parking slot provided outside the building/structure will be quantified only as buffer parking.</i></p> <p>**<i>The following prohibitions on parking slots:</i></p> <ol style="list-style-type: none"> 1. <i>Conversion/change of use/occupancy.</i> 2. <i>Reduction of parking spaces.</i> 3. <i>Encroachment on RROW.</i> 4. <i>Public utility and bulky vehicles.</i> 	

Specific Uses or of Occupancy (refer to Section 1.3 of this Rule)	Reference Uses or Character of Occupancies or Type of Buildings/Structures	Minimum Required Parking Slot, Parking Area and Loading Space Requirements
		(a 12.00 meter long container van plus 6.00 meters length for a long/hooded prime mover) and one (1) loading slot for a standard truck for every 5,000.00 sq. meters of GFA; and provide truck maneuvering area outside of the RROW (within property or lot lines only)
10.2. Division J-2	Other uses not classified in previous sections (PUD, etc.)	Provide parking requirements stipulated for most similar or most related uses/occupancies
	<p data-bbox="654 852 722 881"><i>Note:</i></p> <p data-bbox="654 921 1414 1029"><i>* The parking slot requirements shall be an integral part of buildings/structures and any parking slot provided outside the building/structure will be quantified only as buffer parking.</i></p>	

- d. In computing for parking slots, a **fraction** of 50% and above shall be considered as one (1) car parking slot to be provided. In all cases however, a minimum of one (1) car parking slot shall be provided unless otherwise allowed under this Rule.
- i. **Multi-floor parking garages may serve the 20% parking requirements of the building/structure within 200.00 meter radius**, provided at least 80% of the parking requirements are complied with and integrated in the building design.
 - ii. Special Provision on the Handicapped: For buildings/structures to be provided with features intended for the use or occupancy of the handicapped, the minimum provisions of *Batas Pambansa (BP) Bilang 344* and its Implementing Rules and Regulations (IRR) with respect to parking shall be strictly observed.
- e. Allowed **Off-RROW/Off-Street cum Off-Site Parking** Provision:
- i. In addition to on-site cum **off-RROW** (off-street) parking provisions mandated under this Rule, off-site cum off-street parking facilities may be allowed and considered part of a project provided that such facilities specifically consist of reserved or leased parking slots within a **permanent parking building/structure** and not in a vacant parking lot or parking structure/space for a commercial development and provided further that such parking slots are located no more than 100.00 meters away from a residential building project or are located **no more than 200.00 meters away** from an office or commercial building project.
 - ii. Direct access of parking/loading/utility slots and terminals to the RROW shall be generally disallowed to prevent the usage of the RROW as a maneuvering area.
 - iii. **Traffic generating buildings** such as shopping malls or similar facilities that have very high volumes of pedestrian and vehicular traffic may be located at major intersections or **within 100.00 meters** of such intersections, provided that the distance between the street curb of the ingress/egress of such a commercial lot/property (nearest the

intersection) and the straight curb of the intersection shall not be less than 50.00 meters. (Fig. VII.9.)

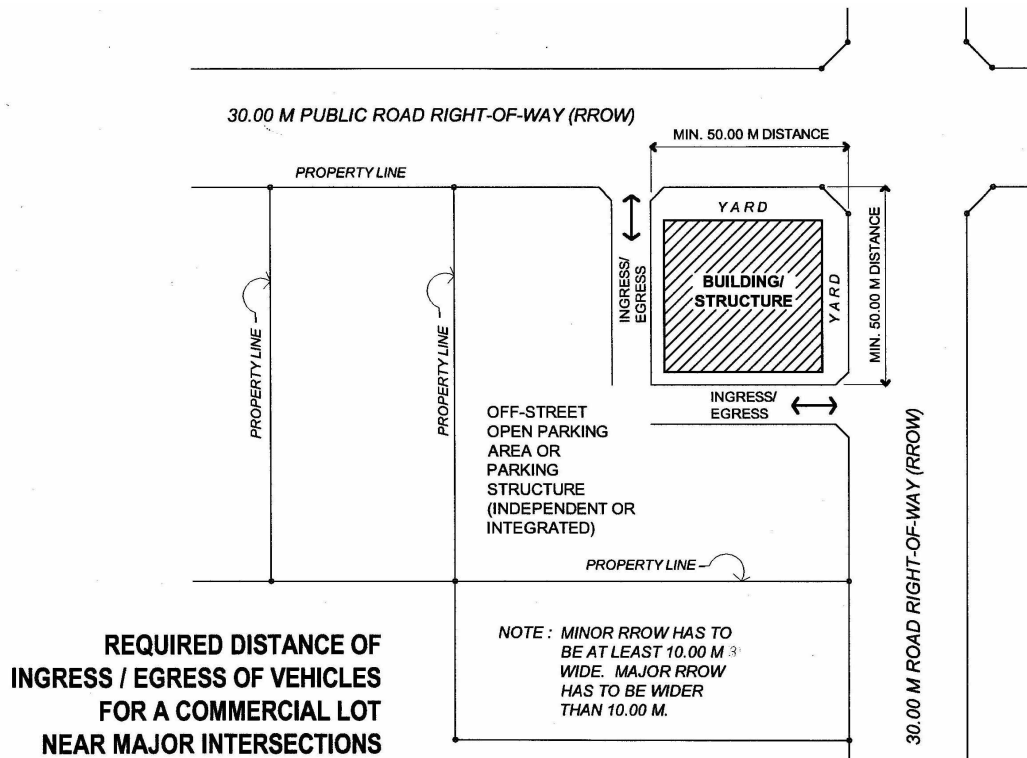

Fig.VII.9.

Annotation. For larger developments and traffic generating buildings as well as parking structures, a minimum 100.00 m distance should be the standard to be considered.

- iv. For **R-2, R-3, GI, C, C-2** and **C-3** uses or occupancies, front yards abutting RROW are not to be used for long-term off-street parking. Due to the very public nature of these uses (high vehicular and pedestrian concentrations), the front yard (a transition space between the RROW and the building/structure) shall be used exclusively for driveways, off-RROW loading spaces, short-term off-RROW parking and landscaping (hardscape and softscape) treatment. Temporary or short-term off-street parking, particularly on driveways, shall preferably be only for visitors to these buildings/structures.
- v. For **Basic R-2** and **Basic R-3** uses or occupancies (for single family dwelling units only), up to 50% of the front yard abutting the RROW may be paved/hardscaped, i.e., converted into a courtyard for carport use. Such use shall not be permitted in all other uses or occupancies.

SECTION 708. Minimum Requirements for Group A Dwellings

1. Dwelling Location and Lot Occupancy

The dwelling shall occupy not more than 90% of a corner lot and 80% of an inside lot, and subject to the provisions on Easements of Light and View of the **Civil Code** of Philippines, shall be **at least 2.00 meters** from the property line.

2. Light and Ventilation

Every dwelling shall be so constructed and arranged as to provide **adequate light and ventilation** as provided under **Section 805 to Section 811 of the Code**.

3. Sanitation

Every dwelling shall be provided with **at least one sanitary toilet** and adequate washing and drainage facilities.

4. Foundation

Footings shall be of sufficient size and strength to support the load of the dwelling and shall be **at least 250 millimeters thick and 600 millimeters below the surface of the ground.**

5. Post

The dimensions of wooden posts shall be those found in **Table VII.5:** Dimensions of Wooden Posts. Each post shall be anchored to such footing by straps and bolts of adequate size.

Table VII.5: Dimensions of Wooden Posts or Suportales

Type Building	Maximum Height of 1st Floor (meters)	Maximum Height Total (meters)	Maximum Spacing of Post (meters)	Required Maximum Finished Size of Suportales (millimeters)
1-Storey Shed	-	4.00	3.50	100 X 100
1-Storey Shed	-	3.00	4.00	100 X 100
1-Storey Shed	-	5.00	4.00	125 X 125
1-Storey House or Chalet	1.00 - 3.00	5.50	3.60	125 X 125
2-Storey House	3.00	6.00	3.00	125 X 125
2-Storey House	4.50	7.00	4.00	120 X 120
2-Storey House	5.00	8.00	4.50	175 X 175
2-Storey House	-	9.00	4.50	200 X 200

Logs or tree trunk *suportales* may be used as post in indigenous traditional type of construction, *provided* that these are of such sizes and spacing as to sustain vertical loading equivalent at least to the loading capacities of the posts and spacing in this Table.

6. Floor

The live load of the first floor shall be at least 200 kilograms per sq. meter and for the second floor, at least 150 kilograms per sq. meter.

7. Roof

The wind load for roofs shall be at least 120 kilograms per sq. meter for vertical projection.

8. Stairs

Stairs shall be at least 750 millimeters in clear width, with a rise of 200 millimeters and a minimum run of 200 millimeters.

9. Entrance and Exit

There shall be at least one entrance and another one for exit.

10. Electrical Requirements

All electrical installations shall conform to the requirements of the Philippine Electrical Code.

11. Mechanical Requirements

Mechanical systems and/or equipment installations shall be subject to the requirements of the Philippine Mechanical Engineering Code.

SECTION 709. Requirements for Other Group Occupancies

Subject to the provisions of the **Code**, the Secretary shall promulgate rules and regulations for each of the other Group Occupancies covering: allowable construction, height, and area; location on property, exit facilities, light and ventilation, sanitation; enclosures of vertical openings; fire extinguishing systems; and special hazards.

GUIDELINES ON BUILDING BULK, DEVELOPMENT CONTROLS, BUILDINGS AND OTHER ACCESSORY STRUCTURES WITHIN CEMETERIES AND MEMORIAL PARKS

A. DETERMINING BUILDING BULK

1. *General.* **Building bulk** (a volume quantity) shall be generally determined by the application of the **Floor-Lot Area Ratio (FLAR)**, vertically projecting the Allowable Maximum Building Footprint (**AMBF**), establishing the Outermost Faces of Building (**OFB**) and quantifying the Allowable Maximum Volume of Building (**AMVB**). The building bulk may be ultimately governed by the width of the RROW and other applicable provisions for light and ventilation (including incremental setbacks as a result of satisfying natural light and ventilation requirements for RROW and front yards as partly shown in **Table VII.G.1.** hereafter).
2. Application of the **FLAR**. The **FLAR (Table VII.G.1.)** shall be the primary or initial determinant of the building bulk.

Table VII.G.1. Reference Table of Floor to Lot Area Ratio (FLAR) Designations/Rights

Type of Use or Occupancy	Type of Building /Structure	FLAR Designation/Rights
Residential	Residential 1 (R-1)	1.50 (at a 3-storey or 10.00 m BHL)
	Residential 2 (R-2)	
	a. Basic R-2	1.30 up to 1.50 (at a 3-storey or 10.00 m BHL)
	b. Maximum R-2	2.10 up to 3.00 (at a 5-storey or 15.00 m BHL)
	Residential 3 (R-3)	
	a. Basic R-3	1.80 up to 2.10 (at a 3-storey or 10.00 m BHL)
	b. Maximum R-3	7.10 up to 8.10 (at a 12-storey or 36.00 m BHL)
	Individual Lot for Residential 4 (R-4)/Townhouses	1.60 up to 1.80 (at a 3-storey or 10.00 m BHL)
Residential 5(R-5)/ Condominiums	6.00 up to 9.00 (at an 18-storey or 54.00 m BHL)	
Commercial	Commercial 1 (Com-1)	1.70 up to 3.00 (at a 5-storey or 15.00 m BHL)

	Commercial 2 (Com-2)	3.60 up to 9.00 (at a 15-storey or 45.00 m BHL)
	Commercial 3 (Com-3)	9.00 up to 34.00 (at a 60-storey or 180.00 m BHL)
Industrial	Industrial 1 (Ind-1)	1.50 up to 2.50
	Industrial 2 (Ind-2)	2.50 up to 3.00
	Industrial 3 (Ind-3)	3.00 up to 5.00
Institutional	-	2.50
Cultural	-	3.50
Utility/Transportation/Road Rights-of Way (RROW)/ Services	-	2.00 up to 3.00
Parks and Open Recreational Spaces	-	0.50 up to 1.00
Agricultural/Agro-Industrial/Tourism	-	1.80 up to 2.20
Planned Unit Development (PUD)	PUD at a reclamation area close to an operating airport	6.00
	PUD at a reclamation area	6.00 up to 12.00
	PUD at a coastal area	12.00 up to 18.00
	PUD at an inland area very close to an operating airport	6.00 up to 18.00
	PUD at an inland area	9.00 up to 34.00 (at a 60-storey or 180.00 m BHL)
Cemetery	-	0.80
Residential 1	33%	1.50
Residential 2 (Basic), Residential 3 (Basic) and Residential 4	20%	1.25
Residential 2 (Maximum), Residential 3 (Maximum) and Residential 5	16%	1.20
Commercial 1	20%	1.25
Commercial 2	25%	1.33
Commercial 3	33%	1.50
Industrial 1	25%	1.33
Industrial 2 and 3	33%	1.50
Transportation, Utility and Service Areas	33%	1.50
Agricultural and Agro-Industrial	2%-5%	1.03-1.06

3. Establishing the **OFB**. The **OFB** shall be primarily determined by the vertical projections of the outermost faces of the **AMBF** up to a height prescribed by the applicable **BHL**. **Figure VII.G.1** shows the determination of the **angular planes** needed to establish the **outer limits for walls and projections** of the proposed building/structure facing RROW and for their corresponding roof configurations. **Table VII.G.3** also shows the recommended angles or slopes for the angular planes originating from the centerline of the **RROW** for **R-1** and **C-3** properties only. Angles or slopes for other permitted uses/occupancies can be extrapolated from the two (2) examples. (**Figs. VIII.G.1** and **VIII.G.2**)

Table VII.G.3. Reference Table of Angles/Slopes* To Satisfy Natural Light and Ventilation Requirements Along RROW and Front Yards

Type of Use or Occupancy	Width of Road Right-of-Way (RROW)	Angle or Slope of Angular Plane for Buildings/Structures Without Projections**		Angle or Slope of Angular Plane for Buildings/Structures With Projections*	
		Angle from Centerline of RROW (Degrees)	Ratio (Slope)	Angle from Centerline of RROW (Degree)	Ratio (Slope)
Residential 1 (R-1)	8.00 meters	46.5	9 m:8.5m (1.06)	50.0	7.5 m:6.25m (1.20)
	10.00 meters	43.0	9 m:9.5m (0.95)	46.0	7.5 m:7.25m (1.03)
	12.00 meters	40.0	9 m:10.5m (0.86)	43.0	7.5 m:8.25m (0.91)
	14.00 meters	38.0	9 m:11.5m (0.78)	39.0	7.5 m:9.25m (0.81)
	16.00 meters	35.0	9 m:12.5m (0.72)	36.0	7.5m:10.25m (0.73)
	18.00 meters	33.5	9 m:13.5m (0.67)	33.0	7.5m:11.25m (0.67)
	20.00 meters	31.0	9 m:14.5m (0.62)	32.0	7.5m:12.25m (0.61)
Commercial 3 (C-3)	8.00 meters	71.0	48 m:16.5m	- (2.90)	-
	10.00 meters	69.5	48 m:17.5m (2.74)	-	-
Commercial 3 (C-3)	12.00 meters	68.0	48 m:18.5m (2.59)	-	-
	14.00 meters	65.5	48 m:19.5m (2.46)	-	-
	16.00 meters	63.6	48 m:20.5m (2.34)	-	-
	18.00 meters	61.7	48 m:21.5m (2.23)	-	-
	20.00 meters	60.0	48 m:22.5m (2.13)	-	-

NOTE:

* To be used for plotting the angular plane from the grade level centerline of the RROW. The angular plane can also help determine the Allowable Maximum Volume of Building (AMVB) as well as the alternative incremental setback lines. Only the uses/occupancies with the least and heaviest developments (R-1 and C-3 respectively are shown). The angles/slopes of angular planes for all other uses/occupancies in between can be extrapolated.

** Considered projections from the outermost face of the building/structure are eaves, medias aguas (canopy for windows), cantilevers, heavy sign supports (only for applications permitted or consistent with the Code) and the like.

4. Quantifying the **AMVB**. The **AMVB** shall be primarily determined by the following:
 - a. Multiply the **AMBF** (in square meters) for the lot by the applicable **BHL** (in meters) for the lot to arrive at the initial **AMVB** (in cubic meters); the result of this step is the imaginary footprint prism;

- b. Superimpose the angular plane originating from the center of the RROW on the footprint prism; this shall result in the reduction of the initially computed building volume due to the application of incremental setbacks and of roof configuration dictated by the angular plane; the result of this step is the **AMVB**;
- c. To crosscheck the AMVB against the Allowable Maximum TGFA (separately determined), convert the AMVB into its approximate area equivalent (in sq. meters) by dividing it with the BHL. Before converting the AMVB to its area component, check for the effects of the incremental setbacks on the TGFA for each floor of the proposed building/structure.

B. Application of Development Controls (DC)

(To Determine the Maximum Development Potential of a Lot)

1. *Sizing the Building/Structure.* To determine the allowed/appropriate building bulk (volume), the following series of steps using the **DC** under this **Guideline** and other Rules in the **Code** shall be followed:

- a. Refer to **Rule VIII** for prescribed setbacks, yards, courts (at grade level), etc. applicable to the lot/project site; determine the extent of firewall construction if required and/or if permitted; refer to **Rule VIII** for the Percentage of Site Occupancy (**PSO**); compute for the Allowable Maximum Building Footprint (**AMBF**) under this Rule by using the formula:

$$\begin{array}{l} \text{Allowable Maximum} \\ \text{Building/} \\ \text{Footprint or } \mathbf{AMBF} \\ \text{(in sq. meters)} \end{array} = \left[\begin{array}{c} \text{Total} \\ \text{Lot} \\ \text{Area} \\ \mathbf{(TLA)} \end{array} \right] - \left[\begin{array}{c} \text{Land area} \\ \text{required for} \\ \text{yards/ courts} \\ \text{(prescribed} \\ \text{under } \mathbf{Rule} \\ \mathbf{VIII})} \end{array} \right] + \left[\begin{array}{c} \text{Additional buildable} \\ \text{lot area due to} \\ \text{Firewall construction} \\ \text{(if permitted} \\ \text{under this Rule)} \end{array} \right]$$

- b. Check resultant building footprint against applicable **PSO** under Reference **Table VIII.1.** of Rule VIII and consult existing/applicable and/or duly approved zoning ordinances; to check, use the formula:

$$\begin{array}{l} \text{Percentage} \\ \text{of Site} \\ \text{Occupancy } \mathbf{(PSO)} \end{array} = \left[\begin{array}{c} \text{Allowable Maximum} \\ \text{Building Footprint or } \mathbf{AMBF} \\ \text{(in square meters)} \end{array} \right] \div \left[\begin{array}{c} \text{Total} \\ \text{Lot Area} \\ \mathbf{(TLA)} \end{array} \right]$$

- c. Compute for the resultant height of the building/structure by referring to Table VII.2. of this Rule and by using the formula:

$$\begin{array}{l} \text{Resultant Height} \\ \text{of the building/structure} \\ \text{(in meters)} \end{array} = \left[\begin{array}{c} \text{Building Height Limit or the} \\ \mathbf{BHL} \\ \text{(as expressed in number of} \\ \text{floors/storeys)} \end{array} \right] \times \left[\begin{array}{c} \text{Desired} \\ \text{Floor to Floor} \\ \text{Height} \\ \text{(in meters)} \end{array} \right]$$

- d. Check the resultant height against the **BHL** (refer to **Table VII.2.** of this Rule); if a greater building/structure height is desired, consult existing zoning ordinances or other applicable laws for possible relief; if relief cannot be sought, explore sub-grade (basement level) solutions or reduce the desired floor to floor heights in case it is greater than 3.00 meters;
- e. Establish the Outermost Faces of Building (**OFB**) to help determine the Allowable Maximum Volume of Building (**AMVB**) and to satisfy natural light and ventilation requirements for RROW and front yards abutting RROW; an imaginary prism within which the proposed building/structure must fit shall result, unless specifically allowed under the **Code**; thereafter, establish the Outermost Limits of Building Projections (**OLBP**) to fully comply with other applicable light and ventilation provisions;
- f. Initially determine building bulk by computing for the maximum allowable Gross Floor Area (**GFA**) for the building/structure using the formula:

$$\text{Gross Floor Area (GFA) of the building/structure (in square meters)} = \left[\frac{\text{Total Lot Area (TLA)}}{\text{TLA}} \right] \times \left[\frac{\text{Recommended Floor to Lot Area Ratio (FLAR)*}}{\text{FLAR}} \right]$$

NOTE: * Refer to **Table VII.G.1.** of this **Guideline** (**Recommended FLAR Designations/Rights**) and/or consult existing/applicable and duly-approved zoning ordinances.

- i. **GROSS FLOOR AREA (GFA)** - the total floor space within the perimeter of the permanent external building walls (inclusive of main and auxiliary buildings) such as office areas, residential areas, corridors, lobbies and mezzanine level/s. The **GFA** shall also include building projections which may serve as floors or platforms that are directly connected to/integrated with areas within the building/structure, e.g., balconies (Refer to **Section 1004 of Rule X of this IRR**) and the **GFA** excludes the following:
 - (a) Covered areas used for parking and driveways, services and utilities;
 - (b) Vertical penetrations in parking floors where no residential or office units are present; and
 - (c) Uncovered areas for helipads, air-conditioning cooling towers or air-conditioning condensing unit (ACCU) balconies, overhead water tanks, roof decks, laundry areas and cages, wading or swimming pools, whirlpools or *jacuzzis*, terraces, gardens, courts or plazas, balconies exceeding 10.00 sq. meters, fire escape structures and the like.

- g. Determine the Allowable Maximum Total Gross Floor Area (**TGFA**) to approximate building volume using the formula hereafter. In particular, determine the minimum required off-street cum on-site parking provisions, driveways and related access systems, particularly for new developments and/or re-developments whereby provisions of this Guideline shall apply.

Total Gross Floor Area (TGFA) of the building/structure (in sq. meters)	=	Gross Floor Area (GFA) of the building/structure (in square meters)	+	Non- GFA areas*	-	All requirements for courts at all floors (above grade) under Rule VIII (in square meters)
--	---	--	---	------------------------	---	---

NOTE: * Compute for all other areas not covered by the **FLAR** or by the **GFA** using **Table VII.G.2.**

- i. **TOTAL GROSS FLOOR AREA (TGFA)** - the total floor space within the main and auxiliary buildings primarily consisting of the **GFA** and all other enclosed support areas together with all other usable horizontal areas/surfaces above and below established grade level that are all physically attached to the building/s which shall consists of the following:
 - (a) Covered areas used for parking and driveways, services and utilities. The **TGFA** specifically excludes provisions for courts above grade level;
 - (b) Vertical penetrations in parking floors where no residential or office units are present;
 - (c) Uncovered areas for helipads, air-conditioning cooling towers or ACCU balconies, overhead water tanks, roof decks, laundry areas and cages, wading or swimming pools, whirlpool or *jacuzzis*, terraces, gardens, courts or plazas, balconies exceeding 10.00 sq. meters, fire escape structures and the like; and
 - (d) Other building projections which may additionally function as floors or platforms if properly reinforced, e.g., the top surfaces of roof extensions/eaves, sun-breakers, large roofed or cantilevered areas such as *porte cocheres*, canopies and the like.

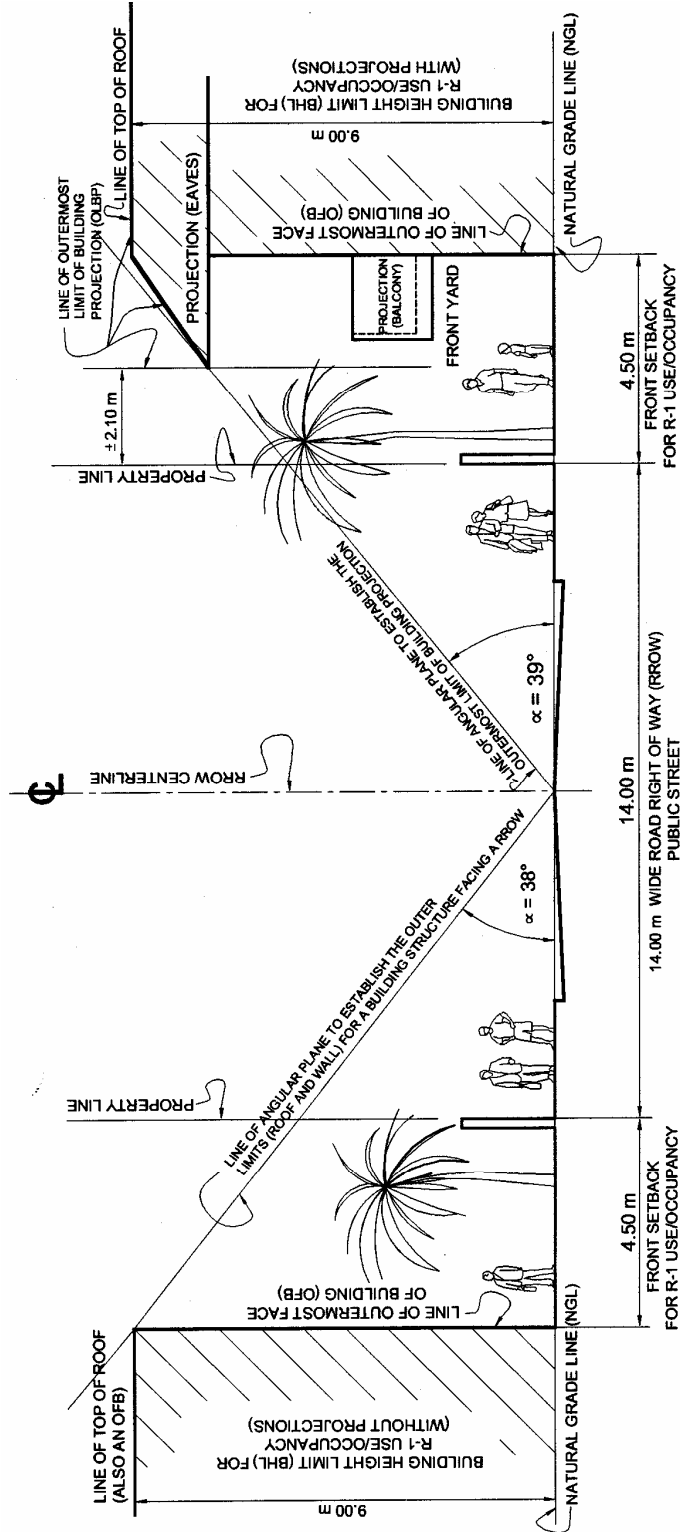

**ANGLES FROM CENTERLINE THAT DETERMINE
THE OFB AND OLBP OF R-1 BUILDINGS/STRUCTURES
(WITH AND WITHOUT PROJECTIONS)
ALONG A 14.00 M RROW**

Figure VII.G.1.

Annotation. Steeper angles shall result if the RROW is narrower, particularly for higher density and higher intensity building uses/occupancies..

Figure VII.G.2.

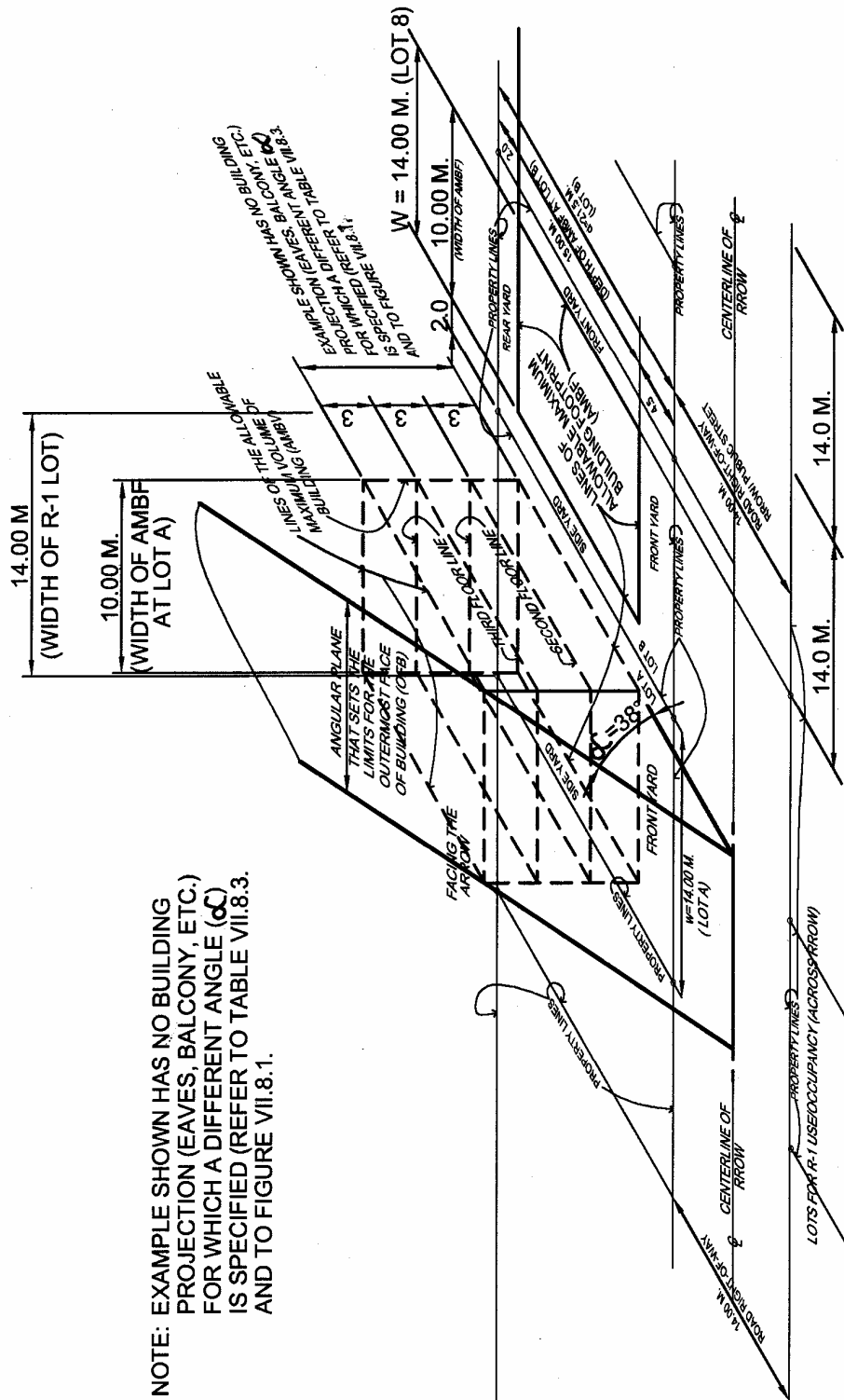

ESTABLISHING THE OUTMOST FACES OF BUILDING (OFB) FOR A TYPICAL R-1 USE / OCCUPANCY THROUGH THE USE OF THE AMBF, THE BHL, THE AMVB AND THE ANGULAR PLANE ALONG THE RROW (14.00 M WIDE RROW)

Annotation. Steeper angles shall result if the RROW is narrower, particularly for higher density and higher intensity building uses/occupancies.

C. BUILDINGS AND OTHER ACCESSORY STRUCTURES WITHIN CEMETERIES AND MEMORIAL PARKS

1. Location of Cemeteries/Memorial Parks

- a. Cemeteries and Memorial Parks shall be located in accordance with the approved land use plan of the city/municipality concerned. Prior clearance shall be obtained from the Department of Health, the National Water Resources Council, the Department of Environment and Natural Resources and the Housing and Land Use Regulatory Board.

2. Protective Enclosures

- a. The cemetery shall be totally enclosed by a perimeter fence/wall of strong material, and all gates shall be provided with a strong door and lock. Perimeter wall shall not exceed 3.00 meters in height.
- b. Where a cemetery is enclosed by a solid reinforced concrete wall at least 2.00 meters high, it is allowed to construct tombs, vaults, mausoleums or other types of sepulchres for the dead up to the walls. Otherwise, a clearance of 5.00 meters shall be maintained between the perimeter fence and the nearest interment plot.

3. Interments, Burials and Entombments

- a. For ground interments, there shall be a minimum depth of excavation of 1.50 meters from ground level to base of excavation. However, if concrete vaults are used, the minimum depth of excavation from base of vault to ground level shall be 1.00 meter, depending on the depth of ground water table.
- b. Ground interments shall be allowed only in designated graveyard areas of the cemetery and may be provided with suitable markers, headstones or memorials.
- c. Vaults for tombs and mausoleums for aboveground interments shall be of solid reinforced concrete. Concrete hollow blocks or any unit masonry construction of ceramics, adobe or the like shall not be allowed for the construction of above-ground vaults; tombs or mausoleums. Mausoleums may be provided with ossuaries and/or cineraria along the interior walls.
- d. Multi-level interment niches shall only be of solid reinforced concrete construction, of not less than 150 millimeters thickness in which case they may be allowed to abut walls of the cemetery, *provided*, the walls are of solid reinforced concrete construction. Concrete hollow blocks, or any unit masonry construction of ceramics, adobe or the like shall not be allowed.
- e. Before construction is started on any mausoleum, canopy over a tomb, or multi-level niches, a building permit shall be secured therefor from the **OBO**.
- f. Horizontal divisions of columbaria shall be of reinforced concrete of at least 50 millimeters thickness. Vertical divisions may be of concrete hollow blocks of at least 100 millimeters thickness, in which case, cement mortar shall be applied evenly to present a non-porous surface. Minimum dimensions of individual cinerarium shall be 300 millimeters by 300 millimeters by 460 millimeters. Cinerary remains shall be placed inside tightly sealed urns.

4. Accessory Structures

- a. A chapel with a floor area of at least 50.00 sq. meters shall be constructed at a convenient location within the cemetery where funeral ceremonies may be held, and incidentally serve as haven for funeral participants against sun and rain.
- b. Wake chaplets with a minimum area of 50.00 sq. meters for thirty (30) persons and at least 1.60 sq. meters for each additional person may be provided.
- c. Administrative Office - a 64.00 sq. meters lot shall be allocated for an administration building office for memorial parks with an area of above one (1) hectare.
- d. Electrical Power Supply - Distances of lampposts for street lighting shall be placed at a maximum of 100.00 meters or as prescribed by the power firm servicing the area. Utility poles shall be installed along sides of streets and pathways.
- e. Parking Area - Parking area equivalent to a minimum of five 5% of the gross area of memorial park/cemetery shall be provided over and above the required parking area/facility for any structures to be constructed within the premises of the memorial park/cemetery.
- f. Comfort Rooms - Adequate and clean comfort rooms with facilities for disabled persons shall be provided in properly located areas.

NOTE: Refer also to the latest applicable **HLURB Guidelines** regarding Cemeteries and Memorial Parks.

(emphases, underscoring and annotations supplied)

Rule VIII follows